

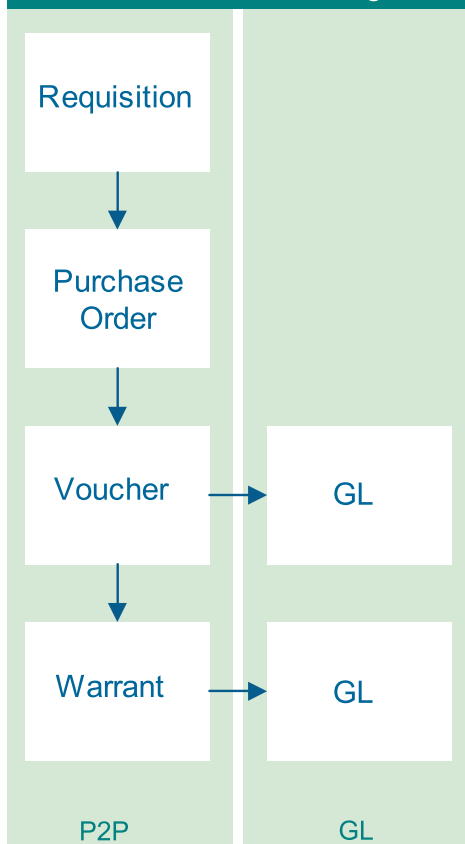

Mission: Empowering Florida's leaders with the financial information they need to make decisions that affect people's lives.

Cycle 1: Intra-Module with GL Integration



Example 1

For more information about System Test – Cycle 1, please see the presentation delivered to the Aspire Executive Committee on October 9th that is available on the Aspire website at http://aspire.dfs.state.fl.us/Meetings_and_Workshops/docs/ec/2006_October_9_Cycle_One_System_Test.pdf.

Aspire System Test – Cycle 1 In Progress

The Project Aspire Team began the execution of **System Test – Cycle 1** on Monday, October 16th. The objectives of this cycle are to:

- Validate that the Aspire system meets the agreed upon design;
- Validate system functionality within various modules;
- Test system configuration;
- Create a library of test scripts that can be leveraged for User Acceptance Testing (UAT);
- Provide Project Aspire state resources hands-on time with the system.

Cycle 1 will continue until December 8th and will focus on testing functional components of Aspire within each individual module as well as Enterprise and a subset of Agency configuration components (see Example 1). System Test – Cycle 2 will begin after Cycle 1 is complete and will include the testing of functionality across Aspire modules (see Example 2).

Cycle 2: Inter-Module with Process Integration

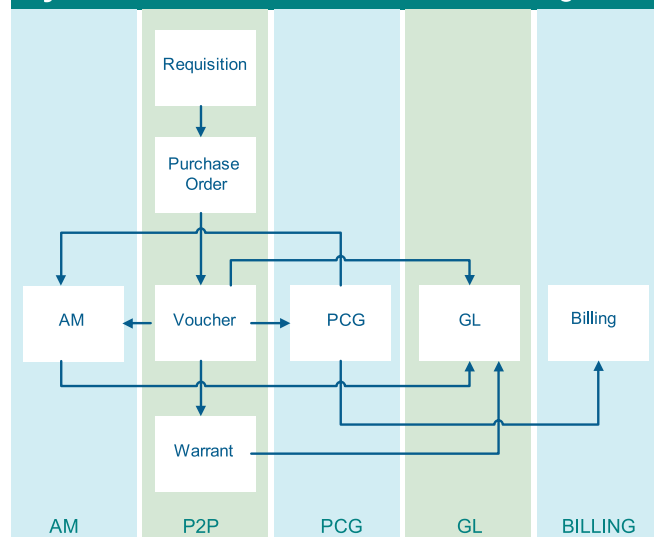

Example 2

Agency Activities Update

Agency Advocates continue to contribute proactively to the preparations for the successful implementation of Aspire. This month, Agency Advocates collaborated with Project Aspire's Agency Implementation Support Team and identified key activities that Advocates will engage in to increase their knowledge of the Aspire system. Examples of these activities and their purposes include:

Functional/Technical Specification and Interface Operations Guide (IOG) Review – Advocates will review Aspire functional and technical specifications as well as IOGs to ensure consistency across these documents.

Enterprise Policy Development – Advocates will assist with the creation of policy documentation in collaboration with the Department of Financial Services' Division of Accounting and Auditing and streamline the process for gathering Agency input about how each policy will impact state Agencies.

Support Question and Answer Repository (QAR) Clean-up – The QAR contains Agency inquiries and responses about the Aspire system that have been compiled over the past year. Advocates will identify unrelated and outdated questions to be purged from the QAR and assist with the development of answers for important and frequently asked questions which will be made available to the Agencies.

Agency Risk & Issue Support – Agency Advocates will participate in the Agency Risk and Issues Task Force to provide their concerns and perspectives on Agency issues and risks relating to the Aspire system. Agency Advocates will provide input to assist fellow Advocates with risk and issue mitigation.

Support Training Development – Advocates will provide the Aspire Training Team with potential scenarios and examples relevant to Aspire users to help validate scenarios and information that will be included in the Aspire training materials.

Agency Advocates will also have opportunities to participate in upcoming learning events focusing on topics such as: Procure to Pay (P2P) Business Process Design, reporting solutions, and Record to Report (R2R) Business Process Design. These events will help to further increase Agency Advocate familiarity with the Aspire system.

For more details about these and other Agency activities please see the Advocate Activities Matrix located at http://aspire.dfs.state.fl.us/Meetings_and_Workshops/docs/IWG/IWG_101806_Advocate_Activity_Matrix.pdf.

Florida Government and Technology Conference

Project Aspire team members conducted information sessions at the Florida Government Technology Conference last month at the Leon County Civic Center. Four identical sessions were held over two days. The sessions covered:

- Project Aspire Vision and Technical Overview
- Overview of Aspire Financial and Reporting Modules
- Agency and Florida Financial Management Information Systems (FFMIS) Interfaces with Aspire
- Aspire User Training and the Learning Management System
- Agency Implementation Strategy

You can view the [Presentation](#) and the [Handout](#) from the Aspire website home page at <http://aspire.dfs.state.fl.us>

Integration Architecture Diagram

The Aspire Integration Architecture diagram visually depicts the inbound and outbound interfaces between the Aspire modules, Agency systems, Florida Financial Management Information Systems (FFMIS) and external entities.

To print the diagram click the link below.

http://aspire.dfs.state.fl.us/Project_Documentation/docs/Aspire_integration_diagram_with_ADML_legend.pdf

To view an animated version of the Aspire Integration Architecture diagram click the following link: http://aspire.dfs.state.fl.us/Project_Documentation/docs/Aspire_integration_Diagram_animated.ppt.



**Time Until
Wave 1 Go-Live
July 2, 2007**

**36
weeks**

Events

Integration Management Council (IMC)

The Integration Management Council (IMC) has been established as a forum for strategic discussion and resolution of Agency technical issues. The intent of the IMC is to have full representation from all Agencies to provide an opportunity to share concerns, suggestions, and lessons learned as Agencies remediate their business systems.

DATE: October 25th
 TIME: 10:00a.m. – 11:00a.m.
 LOCATION: Department of Transportation,
 Burns Auditorium
 605 Suwannee Street, Tallahassee, FL

Executive Committee (EC)

The Executive Committee provides sponsorship and representation from Agency senior financial leadership for the Project and advises the State Project Director to promote the successful implementation of Aspire.

DATE: November 13th
 TIME: 3:00p.m. – 4:00p.m.
 LOCATION: Koger Executive Center,
 Alexander Building, Rm. 230 AB
 2020 Capital Circle S.E., Tallahassee, FL

Inter-Agency Workgroup (IWG)

The Inter-Agency Workgroup provides a forum for Agency and Project staff to discuss Project activities and Agency involvement in these activities. The goal of the IWG is to facilitate Agency preparations for the implementation of Aspire.

DATE: November 15th
 TIME: 1:30p.m. – 3:30p.m.
 LOCATION: Betty Easley Conference Center, Rm. 148
 4075 Esplanade Way, Tallahassee, FL

Meeting agendas will be available on the Aspire website at http://aspire.dfs.state.fl.us/Meetings_and_Workshops. Additionally, meeting presentations are available two hours before each meeting.